

SIEMENS



SIMATIC

S7-1500/ET 200MP

Technology Module TM PTO 4 (6ES7553-1AA00-0AB0)

Manual

Edition

12/2016

Answers for industry.

SIEMENS

SIMATIC

S7-1500/ET 200MP Technology Module TM PTO 4 (6ES7553-1AA00-0AB0)

Manual

Preface

Documentation guide

1

Product overview

2

Connecting

3

Configuring/address space

4

Interrupts/diagnostic alarms

5

Technical specifications

6

Dimensional drawing

A



Parameter data record

B

Legal information

Warning notice system

This manual contains notices you have to observe in order to ensure your personal safety, as well as to prevent damage to property. The notices referring to your personal safety are highlighted in the manual by a safety alert symbol, notices referring only to property damage have no safety alert symbol. These notices shown below are graded according to the degree of danger.

 DANGER
indicates that death or severe personal injury will result if proper precautions are not taken.
 WARNING
indicates that death or severe personal injury may result if proper precautions are not taken.
 CAUTION
indicates that minor personal injury can result if proper precautions are not taken.
NOTICE
indicates that property damage can result if proper precautions are not taken.

If more than one degree of danger is present, the warning notice representing the highest degree of danger will be used. A notice warning of injury to persons with a safety alert symbol may also include a warning relating to property damage.

Qualified Personnel

The product/system described in this documentation may be operated only by **personnel qualified** for the specific task in accordance with the relevant documentation, in particular its warning notices and safety instructions. Qualified personnel are those who, based on their training and experience, are capable of identifying risks and avoiding potential hazards when working with these products/systems.

Proper use of Siemens products

Note the following:

 WARNING
Siemens products may only be used for the applications described in the catalog and in the relevant technical documentation. If products and components from other manufacturers are used, these must be recommended or approved by Siemens. Proper transport, storage, installation, assembly, commissioning, operation and maintenance are required to ensure that the products operate safely and without any problems. The permissible ambient conditions must be complied with. The information in the relevant documentation must be observed.

Trademarks

All names identified by ® are registered trademarks of Siemens AG. The remaining trademarks in this publication may be trademarks whose use by third parties for their own purposes could violate the rights of the owner.

Disclaimer of Liability

We have reviewed the contents of this publication to ensure consistency with the hardware and software described. Since variance cannot be precluded entirely, we cannot guarantee full consistency. However, the information in this publication is reviewed regularly and any necessary corrections are included in subsequent editions.

Preface

Purpose of the documentation

This manual includes module-specific information on wiring, diagnostics and the technical specifications of the technology module.

Generally-applicable information on installation and commissioning of the S7-1500 or ET 200MP is available in System Manual "S7-1500, ET 200MP Automation System".

Conventions

Please observe notes marked as follows:

Note

A note contains important information on the product described in the documentation, on the handling of the product and on the section of the documentation to which particular attention should be paid.

Security information

Siemens provides products and solutions with industrial security functions that support the secure operation of plants, systems, machines and networks.

In order to protect plants, systems, machines and networks against cyber threats, it is necessary to implement – and continuously maintain – a holistic, state-of-the-art industrial security concept. Siemens' products and solutions only form one element of such a concept.

Customer is responsible to prevent unauthorized access to its plants, systems, machines and networks. Systems, machines and components should only be connected to the enterprise network or the internet if and to the extent necessary and with appropriate security measures (e.g. use of firewalls and network segmentation) in place.

Additionally, Siemens' guidance on appropriate security measures should be taken into account. For more information about industrial security, please visit (<http://www.siemens.com/industrialsecurity>).

Siemens' products and solutions undergo continuous development to make them more secure. Siemens strongly recommends to apply product updates as soon as available and to always use the latest product versions. Use of product versions that are no longer supported, and failure to apply latest updates may increase customer's exposure to cyber threats.

To stay informed about product updates, subscribe to the Siemens Industrial Security RSS Feed under (<http://www.siemens.com/industrialsecurity>).

Open Source Software

Open-source software is used in the firmware of the product described. Open Source Software is provided free of charge. We are liable for the product described, including the open-source software contained in it, pursuant to the conditions applicable to the product. Siemens accepts no liability for the use of the open source software over and above the intended program sequence, or for any faults caused by modifications to the software.

For legal reasons, we are obliged to publish the original text of the license conditions and copyright notices. Please read the information on this on the Internet (<https://support.industry.siemens.com/cs/ww/en/view/109740777>).

Table of contents

	Preface	4
1	Documentation guide	7
2	Product overview	11
2.1	Properties	11
2.2	Functions	14
2.2.1	Pulse Train Output (PTO)	14
2.2.2	Isochronous mode	16
3	Connecting	17
3.1	Pin assignment	17
4	Configuring/address space	26
4.1	Configuring	26
4.2	Reaction to CPU STOP	28
4.3	Address space	28
4.4	Parameters	29
4.5	Control and feedback interface	34
4.5.1	Assignment of the control interface	34
4.5.2	Assignment of the feedback interface	38
4.5.3	Enabling the pulse output	42
5	Interrupts/diagnostic alarms	44
5.1	Status and error displays	44
5.2	Diagnostic alarms	47
6	Technical specifications	49
A	Dimensional drawing	54
B	Parameter data record	56
B.1	Parameter assignment and structure of the parameter data record	56
B.2	Parameter validation error	61

Documentation guide

The documentation for the SIMATIC S7-1500 automation system, the CPU 1516pro-2 PN based on SIMATIC S7-1500 and the SIMATIC ET 200MP distributed I/O system is arranged into three areas.

This arrangement enables you to access the specific content you require.

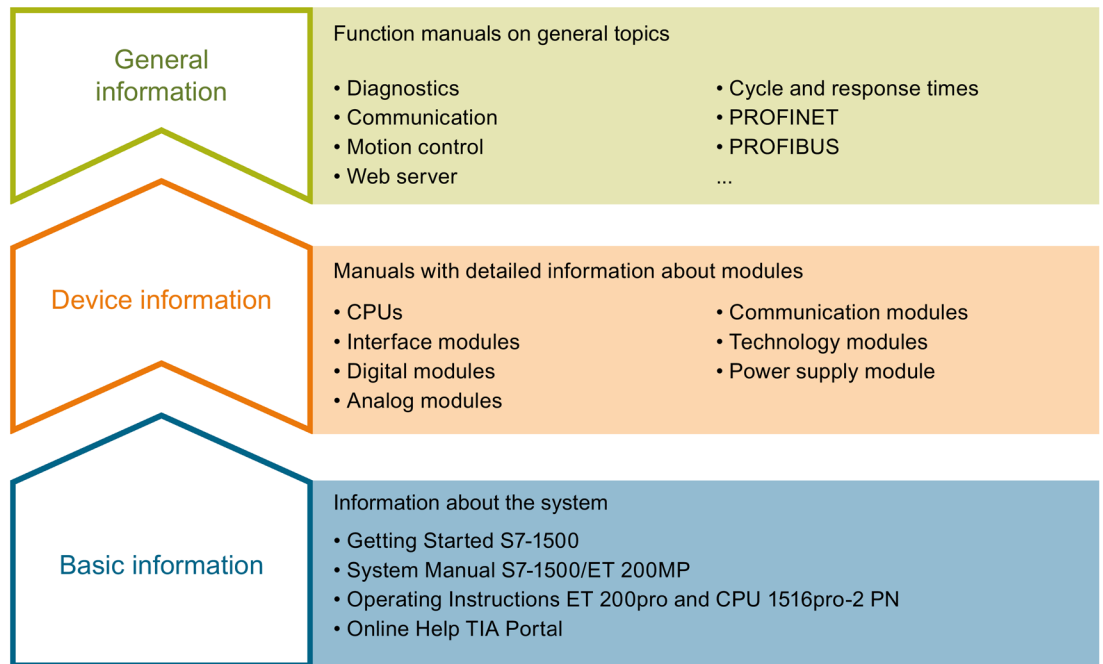

Basic information

The System Manual and Getting Started describe in detail the configuration, installation, wiring and commissioning of the SIMATIC S7-1500 and ET 200MP systems. For CPU 1516pro-2 PN you use the corresponding operating instructions. The STEP 7 online help supports you in the configuration and programming.

Device information

Product manuals contain a compact description of the module-specific information, such as properties, wiring diagrams, characteristics and technical specifications.

General information

The function manuals contain detailed descriptions on general topics regarding the SIMATIC S7-1500 and ET 200MP systems, e.g. diagnostics, communication, motion control, Web server, OPC UA.

You can download the documentation free of charge from the Internet (<http://w3.siemens.com/mcms/industrial-automation-systems-simatic/en/manual-overview/Pages/Default.aspx>).

Changes and supplements to the manuals are documented in a Product Information.

You can download the product information free of charge from the Internet (<https://support.industry.siemens.com/cs/us/en/view/68052815>).

Manual Collection S7-1500/ET 200MP

The Manual Collection contains the complete documentation on the SIMATIC S7-1500 automation system and the ET 200MP distributed I/O system gathered together in one file.

You can find the Manual Collection on the Internet (<https://support.industry.siemens.com/cs/ww/en/view/86140384>).

SIMATIC S7-1500 comparison list for programming languages

The comparison list contains an overview of which instructions and functions you can use for which controller families.

You can find the comparison list on the Internet (<https://support.industry.siemens.com/cs/ww/en/view/86630375>).

"mySupport"

With "mySupport", your personal workspace, you make the best out of your Industry Online Support.

In "mySupport", you can save filters, favorites and tags, request CAx data and compile your personal library in the Documentation area. In addition, your data is already filled out in support requests and you can get an overview of your current requests at any time.

You must register once to use the full functionality of "mySupport".

You can find "mySupport" on the Internet (<https://support.industry.siemens.com/My/ww/en>).

"mySupport" - Documentation

In the Documentation area in "mySupport" you can combine entire manuals or only parts of these to your own manual.

You can export the manual as PDF file or in a format that can be edited later.

You can find "mySupport" - Documentation on the Internet (<http://support.industry.siemens.com/My/ww/en/documentation>).

"mySupport" - CAx data

In the CAx data area in "mySupport", you can access the current product data for your CAx or CAe system.

You configure your own download package with a few clicks.

In doing so you can select:

- Product images, 2D dimension drawings, 3D models, internal circuit diagrams, EPLAN macro files
- Manuals, characteristics, operating manuals, certificates
- Product master data

You can find "mySupport" - CAx data on the Internet (<http://support.industry.siemens.com/my/ww/en/CAxOnline>).

Application examples

The application examples support you with various tools and examples for solving your automation tasks. Solutions are shown in interplay with multiple components in the system - separated from the focus on individual products.

You will find the application examples on the Internet (<https://support.industry.siemens.com/sc/ww/en/sc/2054>).

TIA Selection Tool

With the TIA Selection Tool, you can select, configure and order devices for Totally Integrated Automation (TIA).

This tool is the successor of the SIMATIC Selection Tool and combines the known configurators for automation technology into one tool.

With the TIA Selection Tool, you can generate a complete order list from your product selection or product configuration.

You can find the TIA Selection Tool on the Internet (<http://w3.siemens.com/mcms/topics/en/simatic/tia-selection-tool>).

SIMATIC Automation Tool

You can use the SIMATIC Automation Tool to run commissioning and maintenance activities simultaneously on various SIMATIC S7 stations as a bulk operation independently of the TIA Portal.

The SIMATIC Automation Tool provides a multitude of functions:

- Scanning of a PROFINET/Ethernet network and identification of all connected CPUs
- Address assignment (IP, subnet, gateway) and station name (PROFINET device) to a CPU
- Transfer of the date and the programming device/PC time converted to UTC time to the module
- Program download to CPU
- Operating mode switchover RUN/STOP
- Localization of the CPU by means of LED flashing
- Reading out CPU error information
- Reading the CPU diagnostic buffer
- Reset to factory settings
- Updating the firmware of the CPU and connected modules

You can find the SIMATIC Automation Tool on the Internet (<https://support.industry.siemens.com/cs/ww/en/view/98161300>).

PRONETA

With SIEMENS PRONETA (PROFINET network analysis), you analyze the PROFINET network during commissioning. PRONETA features two core functions:

- The topology overview independently scans PROFINET and all connected components.
- The IO check is a fast test of the wiring and the module configuration of a system.

You can find SIEMENS PRONETA on the Internet (<https://support.industry.siemens.com/cs/ww/en/view/67460624>).

Product overview

2.1 Properties

Article number

6ES7553-1AA00-0AB0

View of the module

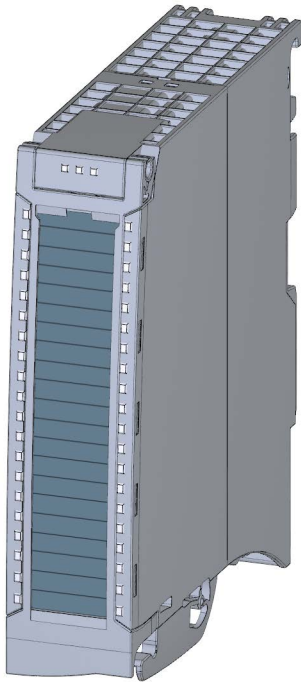

Figure 2-1 View of the TM PTO 4 module

Introduction

The technology module enables you to connect up to four stepper motor axes to an S7-1500 system. The module is linked to technology objects by means of an implementation of the PROFIdrive frame 3 and forms the interface to the drive. The number of steps that are output is returned as the actual position value.

Properties

The TM PTO 4 technology module has the following properties:

- Technical properties
 - 4 channels, quantity can be configured, channel-by-channel parameter assignment
 - Interfaces:
 - RS422/TTL(5 V) or 24 V pulse output signals P/A and D/B for the PTO function (per channel, max. 1 MHz for RS422, max. 200 kHz for 24 V / TTL (5 V))
 - Digital input signals DI0 and DI1 for the reference switch, measuring input, ready input functions (per channel)
 - Digital output signal DQ0 for the PTO or drive enable function (per channel)
 - Digital output signal DQ1 for the PTO function (per channel)
 - Digital input/output signal DIQ2 for the drive enable or ready input function (per channel)
 - Supply voltage L+
 - Configurable diagnostics (per channel)
 - Configurable interpulse period for auto reverse
 - Configurable input delay: none, 0.05 ms ... 20 ms
- Supported signal types for pulse output
 - Pulse encoder with direction signal
 - Pulse encoder with forward signal and backward signal
 - Incremental encoder with two signals with a 90° phase shift
- Supported system functions
 - Isochronous mode
 - Firmware Update
 - Identification data I&M

Accessories

The following components are supplied with the technology module and can also be ordered separately as spare parts:

- Shield bracket
- Shield clamp
- Infeed element
- Labeling strip
- U-connector

Other components

The following component needs to be ordered separately:

- Front connectors, including potential jumpers and cable ties

See also

For more information on accessories, see System Manual S7-1500, ET 200MP Automation System (<http://support.automation.siemens.com/WW/view/en/59191792>).

2.2 Functions

2.2.1 Pulse Train Output (PTO)

Applications

Pulse Train Output is a simple and universal interface between a SIMATIC controller and a drive. PTO is supported worldwide by many stepper and servo drives and is used in many positioning applications, such as for adjustment axes and feed axes.

PTO is also referred to as the pulse/direction interface. The pulse/direction interface comprises two signals. The frequency of the pulse output represents the speed and the number of pulses that are output represents the distance to be traversed. The direction output defines the traversing direction. The position specification is thereby accurate to within one increment. The pulse/direction interface is especially well-suited for operation with the technology objects TO_SpeedAxis, TO_PositioningAxis and TO_SynchronousAxis.

Control

The control of the pulse output channels is provided above all with S7-1500 Motion Control by means of the technology objects TO_SpeedAxis, TO_PositioningAxis and TO_SynchronousAxis . The control and feedback interface (Page 34) of the channels is an implementation of the PROFIdrive interface with standard frame 3.

For a detailed description of configuring the technology module with the axis technology objects, see Function Manual S7-1500T Motion Control, section "Configuring", which is available for download on the Internet

<https://support.industry.siemens.com/cs/ww/en/view/109481326>.

Signal types

The technology module supports the following four signal types:

- Pulse (P) and direction (D):
One output (P) controls the pulses and one output (D) controls the direction. D is 'high' (active) when pulses are generated in the negative direction. D is 'low' (inactive) when pulses are generated in the positive direction.

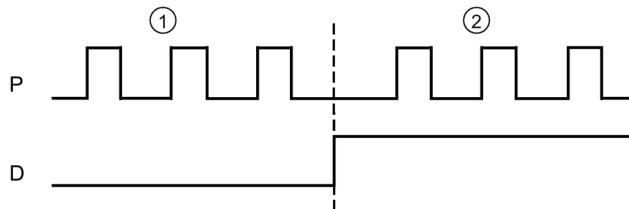

- ① Positive direction of rotation
- ② Negative direction of rotation

- Count up (A), count down (B):
One output (A) outputs pulses for positive directions and another output (B) outputs pulses for negative directions.

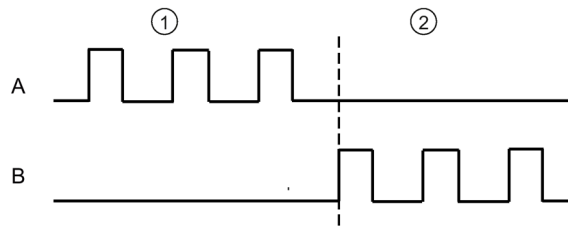

- ① Positive direction of rotation
- ② Negative direction of rotation

- Incremental encoder (A, B phase-shifted):
Output pulses are output by both outputs at the specified velocity, but phase-shifted by 90 degrees. This involves a single pulse output in which the duration of the pulse is the time between two transitions of signal A while signal B is in low state. A positive direction of rotation is generated at a positive edge of signal A while signal B is in low state. A negative direction of rotation is generated at a negative edge of signal A while signal B is in low state.

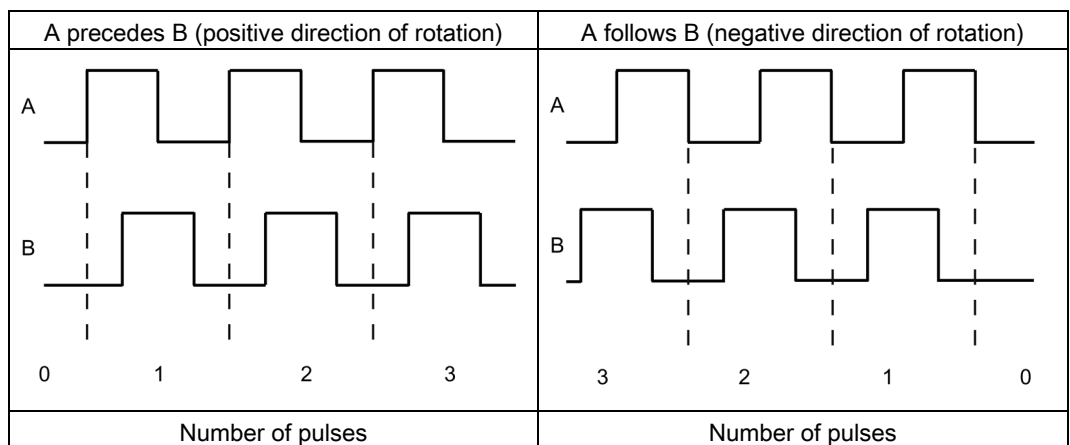

- Incremental encoder (A, B phase-shifted, quadruple):
 Output pulses are output by both outputs at the specified velocity, but phase-shifted by 90 degrees. This signal type involves a quadruple pulse output in which each edge transition corresponds to one increment. Therefore, a complete period of signal A contains four increments. In this way, it is possible, for example, to use two outputs, each with 100 kHz signal frequency, to output a control signal that supplies 400,000 increments per second.
 Whether count pulses are generated in the positive or negative direction of rotation depends on the edge direction of one signal and the logic state of the other signal in each case.

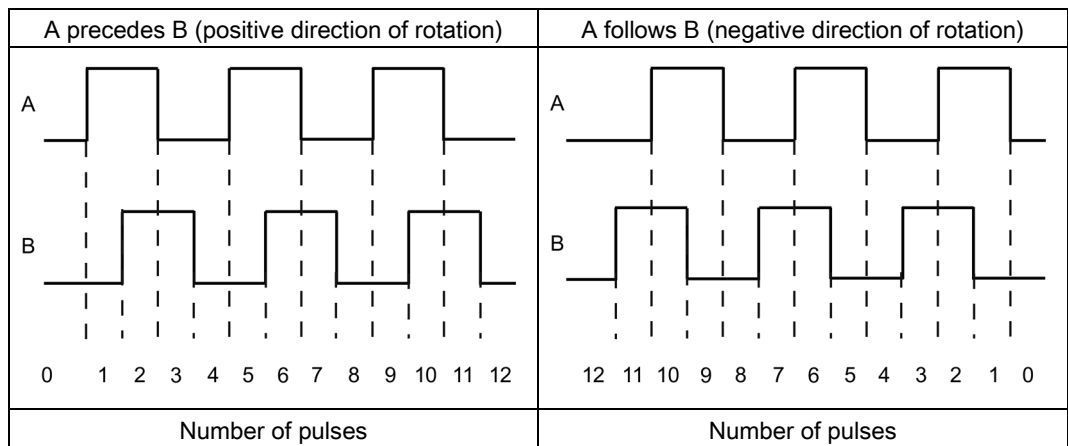

2.2.2 Isochronous mode

The technology module supports the system function "isochronous mode" in distributed mode on PROFINET.

In isochronous mode, the cycle of the user program, the transmission of the input and output data and the processing in the technology module are synchronized with each other.

Data processing

At time T_i the current position value is acquired and made available in the feedback interface for retrieval in the current bus cycle. At time T_o the pulse output is adjusted to the current speed setpoint.

Connecting

3.1 Pin assignment

You connect the pulse output signals, digital input signals and digital output signals to the 40-pin front connector of the technology module. In addition, you connect the supply voltage for supplying the module and the digital outputs to the 4-pin infeed element.

For information on wiring the front connector, connecting the cable shield, etc., see System Manual S7-1500, ET 200MP Automation System (<http://support.automation.siemens.com/WW/view/en/59191792>), section Wiring.

Pin assignment for the front connector

The table below shows the pin assignment of the front connector for the respective signal interface.

Table 3-1 Pin assignment of the front connector

View	Signal name	Designation			
		24 V, asymmetrical	RS422, symmetrical	TTL (5 V), asymmetrical	
	Channel 0				
	1	CH0.P/A	—	Pulse signal P/A	Pulse signal P/A
	2	/CH0.P/A	—	Inverted pulse signal P/A	—
	3	CH0.D/B	—	Pulse signal D/B	Pulse signal D/B
	4	/CH0.D/B	—	Inverted pulse signal D/B	—
	5	DQ0.0	Pulse signal P/A	Digital output DQ0	Digital output DQ0
	6	DQ0.1	Pulse signal D/B	—	—
	7	DI0.0	Digital input DI0		
	8	DI0.1	Digital input DI1		
	9	DIQ0.2	Digital input/output DIQ2		
	Channel 1				
	10	CH1.P/A	—	Pulse signal P/A	Pulse signal P/A
	11	/CH1.P/A	—	Inverted pulse signal P/A	—
	12	CH1.D/B	—	Pulse signal D/B	Pulse signal D/B
	13	/CH1.D/B	—	Inverted pulse signal D/B	—
	14	DQ1.0	Pulse signal P/A	Digital output DQ0	Digital output DQ0
	15	DQ1.1	Pulse signal D/B	—	—
	16	DI1.0	Digital input DI0		
	17	DI1.1	Digital input DI1		
	18	DIQ1.2	Digital input/output DIQ2		
19	—	—			
20	—	—			

3.1 Pin assignment

View	Signal name	Designation		
		24 V, asymmetrical	RS422, symmetrical	TTL (5 V), asymmetrical
Channel 2				
21	CH2.P/A	—	Pulse signal P/A	Pulse signal P/A
22	/CH2.P/A		Inverted pulse signal P/A	—
23	CH2.D/B		Pulse signal D/B	Pulse signal D/B
24	/CH2.D/B		Inverted pulse signal D/B	—
25	DQ2.0	Pulse signal P/A	Digital output DQ0	Digital output DQ0
26	DQ2.1	Pulse signal D/B	—	—
27	DI2.0	Digital input DI0		
28	DI2.1	Digital input DI1		
29	DIQ2.2	Digital input/output DIQ2		
Channel 3				
30	CH3.P/A	—	Pulse signal P/A	Pulse signal P/A
31	/CH3.P/A		Inverted pulse signal P/A	—
32	CH3.D/B		Pulse signal D/B	Pulse signal D/B
33	/CH3.D/B		Inverted pulse signal D/B	—
34	DQ3.0	Pulse signal P/A	Digital output DQ0	Digital output DQ0
35	DQ3.1	Pulse signal D/B	—	—
36	DI3.0	Digital input DI0		
37	DI3.1	Digital input DI1		
38	DIQ3.2	Digital input/output DIQ2		
39	M	Ground for digital outputs, digital inputs and pulse signals of the technology module		
40	M			

Note

Use of jumper links in the front connector is not permitted.

Pin assignment for the infeed element

The infeed element is inserted into the front connector and serves to supply power to the technology module. You must connect the supply voltage to terminal 41 (L+) and terminal 44 (M) for this.

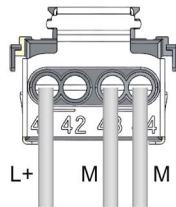

Figure 3-1 Infeed element wiring

L+	24 V DC supply voltage
M	Ground for supply voltage

Behavior of the digital outputs following a wire break at the ground connection of the outputs

Due to the characteristics of the output driver used in the module, a wire break causes approximately 10 mA supply current to drain from the digital outputs via a parasitic diode. This behavior may lead to a high signal state even at outputs that are not set. Depending on the nature of the load, 10 mA may be enough to activate a load with high signal state.

Duplicate wiring of ground

To prevent unintended switching of the outputs in the event of a ground connection wire break, follow these steps:

1. Route the first ground connection from terminal 44 to the ground connection of the central power supply of the system.
2. Route the second ground connection from terminal 43 to the ground connection of the central power supply of the system.

If one of the two ground connection cables is interrupted, the outputs are maintained at the required potential by the remaining ground connection.

WARNING

Wire break at ground connection

Always connect *two* cables to the ground connection of the central power supply of the system.

Circuit diagram

The figure below shows an example circuit diagram of the technology module. In this example, four channels are used with the RS422, 5 V-TTL and 24 V signal interfaces:

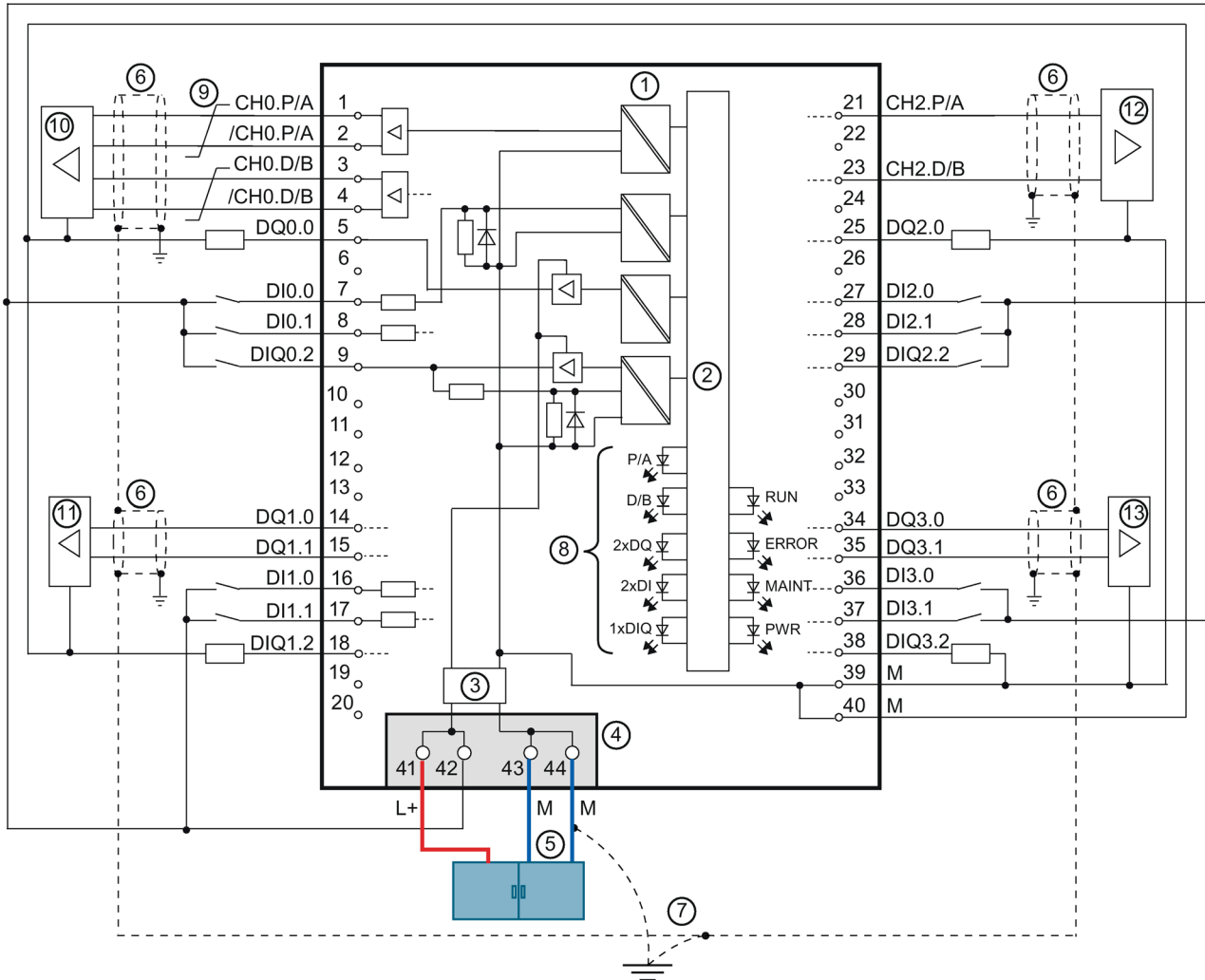

- ① Electrical isolation
- ② Technology and backplane bus interface
- ③ Input filter for supply voltage
- ④ Supply voltage via infeed element
- ⑤ Duplicate wiring to the ground connection of the central power supply of the system
- ⑥ Shield connection at the front connector
- ⑦ Equipotential bonding
- ⑧ LEDs per channel
- ⑨ Twisted-pair cables
- ⑩ Motor with drive stage at RS422 signal interface
- ⑪, ⑬ Motor with drive stage at 24 V signal interface
- ⑫ Motor with drive stage at TTL signal interface

Figure 3-2 Circuit diagram when using RS422, 5 V-TTL and 24 V signal interfaces

Supply voltage L+/M

Connect the supply voltage (24 V DC) to the L+ and M connections. An internal protective circuit protects the technology module from polarity reversal of the supply voltage. The technology module monitors the connection of the supply voltage.

ThePWR LED (Page 44) at terminal 19 indicates the presence of supply voltage.

RS422/TTL and 24 V pulse output signals

The technology module can output pulse signals either via the RS422/TTL or 24 V signal interface for each channel. The pulse signals are designated with P/A and D/B.

A TTL pulse signal and a 24 V pulse signal use a single wire. An RS422 pulse signal uses a pair of wires and the pulse information is transmitted as differential voltage. This ensures interference-free transmission of RS422 encoder signals, even of higher-frequency signals over longer distances. The RS422 wire pairs must be twisted in the cable and terminated with a 100 Ω resistance.

For an overview of the signal types you can output, see section Pulse Train Output (PTO) (Page 14).

When the RS422/TTL signal interface is used, you connect the P/A signal to the Chn.P/A connections and the D/B signal to the CHn.D/B connections. When the 24 V signal interface is used, you connect the P/A signal to digital output DQn.0 and the D/B signal to digital output DQn.1. When the 5 V TTL signal interface is used, you must provide a resistance of 220 Ω to 1 k Ω between connection CHn.P/A and ground M as well as between connection CHn.D/B and ground M.

The outputs of the channels are not electrically isolated from each other. The outputs are electrically isolated from the backplane bus.

Digital inputs DI0, DI1 and DIQ2

Up to three digital inputs are available per channel. The digital inputs are used for additional functions for the respective drive control:

Function	Meaning
Reference switch input	You can use a reference switch at digital input DI _n .0 to synchronize the reference mark with the current position of the drive axis.
Measuring input	You can use a measuring input at digital input DI _n .1 to save the current position of the drive axis.
"Drive ready" input	You can use digital input DI _n .0, DI _n .1 or DIQ _n .2 as an input for the ready signal of the drive.

The digital inputs of the channels are not electrically isolated from each other. The digital inputs are electrically isolated from the backplane bus.

Interpulse period following auto reverse

You can configure the minimum amount of time the technology module must pause the pulse output following reversal of the direction of rotation. After the interpulse period elapses, the pulse output is resumed.

You can specify the following values for the interpulse period:

- 0 (default)
- 1 ms
- 4 ms
- 10 ms

Input delay

This parameter can be used to suppress signal noise at the digital inputs of a channel. Changes to the signal are only detected if they remain stable for longer than the configured input delay time.

You can specify the following values for the input delay:

- None
(input delay of 4 μ s, minimum pulse width of 3 μ s)
- 0.05 ms
- 0.1 ms (default)
- 0.4 ms
- 0.8 ms
- 1.6 ms
- 3.2 ms
- 12.8 ms
- 20 ms

Note

If you select the "None" or "0.05 ms" option, you have to use shielded cables for connection of the digital inputs.

Digital outputs DQ0, DQ1 and DIQ2

Up to three digital outputs are available per channel. When you use the "RS422, symmetrical / TTL (5 V), asymmetrical" signal interface, you can use digital output DQn.0 to enable the drive. When the "24 V, asymmetrical" signal interface is used, you connect the P/A signal to digital output DQn.0 and the D/B signal to digital output DQn.1. In this case, you can use digital output DIQn.2 to enable the drive.

The digital outputs of the channels are not electrically isolated from each other. The digital outputs are electrically isolated from the backplane bus.

The digital outputs are 24 V current-sourcing switches in relation to M. DQn.0 and DQn.1 can be loaded with 0.1 A rated load current and DQn.2 can be loaded with 0.5 A rated load current. The digital outputs are protected from overload and short-circuit.

Note

Relays and contactors can be connected direct without external circuitry.

Possible combinations of the DI and DQ functions

The possible combinations of additional DI and DQ functions are dependent on the signal interface:

- Reference switch input (RS, Reference Switch)
- Measuring input (MI, Measuring Input)
- "Drive ready" input (DR, Drive Ready)
- Drive enable output (ED, Enable Drive)

3.1 Pin assignment

When you use the "RS422, symmetrical / TTL (5 V), asymmetrical" signal interface, you have the following possible combinations for the named functions:

Table 3-2 Possible combinations for "RS422, symmetrical / TTL (5 V), asymmetrical" signal interface

DIn.0	DIn.1	DIQn.2		DQn.0	DQn.1
		Input	Output		
—	—	—	—	—	Not supported
RS	—	—	—	—	
RS	—	DR	—	—	
RS	—	DR	—	ED	
RS	—	—	ED	—	
RS	MI	—	—	—	
RS	MI	DR	—	—	
RS	MI	DR	—	ED	
RS	MI	—	ED	—	
—	MI	—	—	—	
—	MI	DR	—	—	
—	MI	DR	—	ED	
—	MI	—	ED	—	
DR	—	—	—	—	
DR	—	—	—	ED	
DR	—	—	ED	—	
DR	MI	—	—	—	
DR	MI	—	—	ED	
DR	MI	—	ED	—	
—	DR	—	—	—	
—	DR	—	—	ED	
—	DR	—	ED	—	
RS	DR	—	—	—	
RS	DR	—	—	ED	
RS	DR	—	ED	—	

When you use the "24 V, asymmetrical" signal interface, you have the following possible combinations for the named functions:

Table 3- 3 Possible combinations for "24 V, asymmetrical" signal interface

DIn.0	DIn.1	DIQn.2		DQn.0	DQn.1
		Input	Output		
—	—	—	—	P/A signal	D/B signal
RS	—	—	—		
—	—	DR	—		
RS	—	DR	—		
—	—	—	ED		
RS	—	—	ED		
RS	MI	—	—		
RS	MI	DR	—		
RS	MI	—	ED		
—	MI	—	—		
—	MI	DR	—		
—	MI	—	ED		
DR	—	—	—		
DR	—	—	ED		
DR	MI	—	—		
DR	MI	—	ED		
—	DR	—	—		
—	DR	—	ED		
RS	DR	—	—		
RS	DR	—	ED		

Configuring/address space

4.1 Configuring

Introduction

The technology module is configured and assigned parameters with the configuration software.

The technology module functions are controlled and monitored by the user program.

System environment

The technology module can be used in the following system environments:

Table 4- 1 Possible applications of the technology module

Possible applications	Components required	Configuration software	In the user program
Central operation in an S7-1500 system	<ul style="list-style-type: none"> S7-1500 automation system TM PTO 4 	STEP 7 (TIA Portal): <ul style="list-style-type: none"> Device configuration and parameter setting with hardware configuration Parameter setting with axis technology object for Motion Control 	Motion Control instructions
Distributed operation in an S7-1500 system	<ul style="list-style-type: none"> S7-1500 automation system ET 200MP distributed I/O system TM PTO 4 	STEP 7 (TIA Portal): <ul style="list-style-type: none"> Device configuration and parameter setting with hardware configuration Parameter setting with axis technology object for Motion Control (PROFINET IO and PROFIBUS DP¹) 	
Distributed operation in an S7-1200 system	<ul style="list-style-type: none"> S7-1200 automation system ET 200MP distributed I/O system TM PTO 4 	STEP 7 (TIA Portal): <ul style="list-style-type: none"> Device configuration and parameter setting with hardware configuration Parameter setting with TO_PositioningAxis technology object (PROFINET IO and PROFIBUS DP¹) 	
Distributed operation in an S7-300/400 system	<ul style="list-style-type: none"> S7-300/400 automation system ET 200MP distributed I/O system TM PTO 4 	STEP 7 (TIA Portal): Device configuration and parameter setting with hardware configuration (PROFINET IO and PROFIBUS DP ¹) STEP 7: Device configuration and parameter setting of the module with GSD file (PROFINET IO)	Direct access to control and feedback interface (Page 34) of the technology module control in the IO data

Possible applications	Components required	Configuration software	In the user program
Distributed operation in a third-party system	<ul style="list-style-type: none"> Third-party automation system ET 200MP distributed I/O system TM PTO 4 	Third-party configuration software: Device configuration and parameter setting of the module with GSD file (PROFINET IO)	

¹ When using the technology module on PROFIBUS DP, you can use a maximum of three channels.

Control using a technology object

For a detailed description of configuring the technology module with axis technology objects TO_SpeedAxis, TO_PositioningAxis and TO_SynchronousAxis, refer to the following:

- Function Manual S7-1500T Motion Control, section "Configuring", which is available for download on the Internet (<https://support.industry.siemens.com/cs/ww/en/view/109481326>)
- Information system of STEP 7 (TIA Portal), under "Using technology functions > Motion Control > Motion Control (S7-1200, S7-1500, S7-1500T) > Configuring (S7-1500, S7-1500T) > Configuring technology modules for Motion Control (S7-1500, S7-1500T)"

Hardware Support Package (HSP)

If the technology module is not yet integrated in your TIA Portal version, you can integrate it as of TIA Portal V14 with HSP0181.

The Hardware Support Packages (HSP) are available for download on the Internet (<https://support.industry.siemens.com/cs/ww/en/view/72341852>).

Alternatively, they can be accessed for downloading via the menu bar of STEP 7 (TIA Portal): "Options > Support Packages > Download from the Internet".

GSD file for PROFINET IO

The GSD file for the ET 200MP distributed I/O system on PROFINET IO is available for download on the Internet (<https://support.industry.siemens.com/cs/ww/en/view/68189683>).

4.2 Reaction to CPU STOP

The following overview shows the reaction of the technology module to a transition of the CPU to STOP. The reaction is not configurable.

Table 4- 2 Reaction of technology module to CPU STOP

	Reaction of technology module
RUN-STOP transition	<p>The technology module executes a Coast Stop (OFF2), which causes the pulse output to stop. If you are using a drive enable, the corresponding digital output is reset immediately.</p> <p>The control interface is no longer evaluated. The feedback interface continues returning the last acquired values. The feedback interface continues signaling diagnostic information using the Fault_Present and Sensor_Error bits.</p> <p>Active functions, such as for the reference switch, are aborted.</p>
STOP-RUN transition	<p>The configuration of the technology module is not reset. The feedback interface keeps the last acquired position value (G1_XIST1).</p>

4.3 Address space

Address space of the technology module

Table 4- 3 Range of the input addresses and output addresses of the TM PTO 4

Channel configuration	Address space	
	Inputs	Outputs
1 channel	18 bytes	10 bytes
2 channels	36 bytes	20 bytes
3 channels	54 bytes	30 bytes
4 channels	72 bytes	40 bytes

Additional information

For a description of the control and feedback interface of the technology module, see section Control and feedback interface (Page 34).

4.4 Parameters

You can use various parameters to define the properties of the technology module. Depending on the settings, not all parameters are available. When parameters are assigned in the user program, the parameters are transferred to the module with the "WRREC" instruction and data record 128 (Page 56).

You have the following options for setting the module's parameters:

Parameter setting via ...	Basic procedure
Hardware configuration in STEP 7 (TIA Portal) with HSP in the case of centralized operation in an S7-1500 system	<ol style="list-style-type: none"> 1. Install the appropriate HSP file. 2. Select an appropriate CPU under "Add new device > Controller > SIMATIC S7-1500". 3. Select the module in the hardware catalog under "Technology modules". 4. Set the device configuration and the parameters of the module in the hardware configuration. 5. Set the parameters of the technology object. 6. Download the parameter assignment to the module.
Hardware configuration in STEP 7 (TIA Portal) with HSP in the case of distributed operation in an S7-1500 system	<ol style="list-style-type: none"> 1. Install the appropriate HSP file. 2. Select an appropriate IM in the hardware catalog under "Distributed I/O > ET200MP". 3. Select the module in the hardware catalog under "Technology modules". 4. Set the device configuration and the parameters of the module in the hardware configuration. 5. Set the parameters of the technology object. 6. Download the parameter assignment to the module.
Hardware configuration using GSD file for distributed operation on the PROFINET IO	<ol style="list-style-type: none"> 1. Install the current PROFINET GSD file. 2. Select an appropriate IM in the hardware catalog under "Other field devices > PROFINET IO > I/O". 3. Select the module in the hardware catalog under "Technology modules". 4. Set the parameters of the module in the hardware configuration. 5. Download the parameter assignment to the module.

You will find the parameters in the following table.

Parameters of the TM PTO 4

The following parameter settings are possible:

Table 4- 4 Configurable parameters and their defaults

Parameter	Value range	Default setting	Re-configuration in RUN	Effective range with configuration software: HSP or GSD file for PROFINET IO
Channel configuration	<ul style="list-style-type: none"> 4 channels 3 channels 2 channels 1 channel 	4 channels	No	Module
Signal type	<ul style="list-style-type: none"> Pulse (P) and direction (D) Count up (A), count down (B) Incremental encoder (A, B phase-shifted) Incremental encoder (A, B phase-shifted, quadruple) 	Pulse (P) and direction (D)	Yes	Channel
Signal interface	<ul style="list-style-type: none"> 24 V, asymmetrical RS422, symmetrical / TTL (5 V), asymmetrical 	24 V, asymmetrical	Yes	Channel
Interpulse period following auto reverse	<ul style="list-style-type: none"> 0 ms 1 ms 4 ms 10 ms 	0 ms	Yes	Channel
Enable diagnostic interrupts	<ul style="list-style-type: none"> Disabled Enabled 	Disabled	Yes	Channel
Increments per revolution	1...1000000	200	Yes	Channel
Reference speed	1,0...20000,0 U/min	3000,0	Yes	Channel
Maximum speed	Dependent on signal interface, signal evaluation, increments per revolution and reference speed (see following table)	3000,0	Yes	Channel

Parameter	Value range	Default setting	Re-configuration in RUN	Effective range with configuration software: HSP or GSD file for PROFINET IO
Quick stop time (OFF3)	1...65535 ms	1000 ms	Yes	Channel
Ramp stop time (OFF1)	1...65535 ms	5000 ms	Yes	Channel
Use drive enable	<ul style="list-style-type: none"> • Disabled • Enabled 	Disabled	Yes	Channel
Drive enable output	<ul style="list-style-type: none"> • DQ0 • DIQ2 	DQ0	Yes	Channel
Use DI0 as reference switch	<ul style="list-style-type: none"> • Disabled • Enabled 	Disabled	Yes	Channel
Reference switch edge selection	<ul style="list-style-type: none"> • At positive edge • At negative edge 	At positive edge	Yes	Channel
Use DI1 as measuring input	<ul style="list-style-type: none"> • Disabled • Enabled 	Disabled	Yes	Channel
Use "Drive ready"	<ul style="list-style-type: none"> • Disabled • Enabled 	Disabled	Yes	Channel
"Drive ready" input	<ul style="list-style-type: none"> • DI0 • DI1 • DIQ2 	DI0	Yes	Channel
Input delay	<ul style="list-style-type: none"> • None • 0.05 ms • 0.1 ms • 0.4 ms • 0.8 ms • 1.6 ms • 3.2 ms • 12.8 ms • 20 ms 	0.1 ms	Yes	Channel
Tolerated number of sign-of-life errors	0...65535	1	Yes	Channel

4.4 Parameters

The following table shows the calculation of the value range of the maximum speed:

Table 4- 5 Value range of the maximum speed

Signal interface	Value range of the maximum speed			
	Low limit		High limit (the smaller of the two values applies)	
	Signal evaluation "Single"	Signal evaluation "Quadruple"	Signal evaluation "Single"	Signal evaluation "Quadruple"
24 V, asymmetrical	0.1 Hz * 60 / (increments per revolution)	0.1 Hz * 60 * 4 / (increments per revolution)	<ul style="list-style-type: none"> 2 * reference speed 200000 Hz * 60 / (increments per revolution) 	<ul style="list-style-type: none"> 2 * reference speed 200000 Hz * 60 * 4 / (increments per revolution)
TTL (5 V), asymmetrical			<ul style="list-style-type: none"> 2 * reference speed 1000000 Hz * 60 / (increments per revolution) 	<ul style="list-style-type: none"> 2 * reference speed 1000000 Hz * 60 * 4 / (increments per revolution)
RS422, symmetrical				

Description of parameters

Parameter	Description
Channel configuration	Selection of the number of channels used. The channels are assigned in ascending order.
Signal type	Selection of the type of PTO pulse output (Page 14).
Signal interface	Selection of the interface used for the pulse output: <ul style="list-style-type: none"> 24 V, asymmetrical: The channel outputs 24 V signals at terminals DQm.0 and DQm.1. RS422, symmetrical / TTL (5 V), asymmetrical: The channel outputs either RS422 signals at terminals P/A and D/B and the respective inverted terminals or 5 V TTL signals at terminals P/A and D/B.
Interpulse period following auto reverse	Selection of the minimum time between a change in direction and the output of the first pulse in the new direction.
Enable diagnostic interrupts	Enables the following diagnostic interrupts (Page 47): <ul style="list-style-type: none"> Supply voltage missing Error at digital outputs The detected error is indicated for the respective channel with feedback bits (Page 38) Fault_Present and Sensor_Error.
Increments per revolution	Input of the number of steps (also micro steps) that correspond to one revolution of the drive. This parameter must match the "Increments per revolution" parameter in the "Data exchange with encoder" tab of the axis technology object.

Parameter	Description
Reference speed	Input of the speed at which the drive rotates with a speed setpoint of 100%. The permitted value range for the speed setpoint is -200% ... +200%. This parameter must match the "Reference speed" parameter in the "Data exchange with drive" tab of the axis technology object.
Maximum speed	Input of the maximum permitted speed for the application. The value must not exceed twice the reference speed. This parameter must match the "Maximum speed" parameter in the "Data exchange with drive" tab of the axis technology object.
Bits in incr. actual value (G1_XIST1)	Specifies the number of bits for the fine resolution coding in the incremental actual position value G1_XIST1. The value is always "0" for this module. This parameter must match the "Bits in incr. actual value (Gn_XIST1)" parameter in the "Data exchange with encoder" tab of the axis technology object.
Quick stop time (OFF3)	Input of the time taken to execute a fast stop from maximum speed to standstill.
Ramp stop time (OFF1)	Input of the time taken to execute a stop from maximum speed to standstill.
Use drive enable	Enables use of the drive enable signal at a hardware output (Page 17).
Drive enable output	Selection of the hardware output (Page 17) that is used to enable the drive. Only available for selection and effective if "Use drive enable" is enabled.
Use DI0 as reference switch	Enables use of the reference switch signal at the hardware input DI0 (Page 17). You can synchronize the reference mark with the current position of the drive axis using the reference switch signal.
Reference switch edge selection	Selection of the edge at DI0 that triggers detection of the reference mark. Only available for selection and effective if "Use DI0 as reference switch" is enabled.
Use DI1 as measuring input	Enables use of the measuring input signal at hardware input DI1 (Page 17). You can save the current position of the drive axis using the measuring input signal.
Use "Drive ready"	Enables use of the ready signal of the drive at a hardware input (Page 17).
"Drive ready" input	Selection of the hardware input (Page 17) to which the ready signal of the drive is connected and read in. Only available for selection and effective if "Use "Drive ready"" is enabled.
Input delay	Selection of the input delay for the signal at the respective digital input for noise suppression. Changes to the signal are only detected if they remain stable for longer than the configured input delay time. The input delay applies to all the used hardware inputs of the channel.
Tolerated number of sign-of-life errors	Input of how many Master Sign-Of-Life errors are tolerated by the module. If the number is exceeded, this triggers an error message via return bit (Page 38) Sensor_Error. 65535 means: No monitoring for sign-of-life errors

4.5 Control and feedback interface

Direct access to the control and feedback interface is not needed for use of the module in an S7-1500 or S7-1200 system. For this case an S7-1500 system has the TO_SpeedAxis, TO_PositioningAxis and TO_SynchronousAxis technology objects, and an S7-1200 system has the TO_PositioningAxis technology object. For a detailed description of configuring the technology module with the axis technology objects, see Function Manual S7-1500T Motion Control, section "Configuring", which is available for download on the Internet (<https://support.industry.siemens.com/cs/ww/en/view/109481326>).

The control and feedback interface of the channels is a partial implementation of the PROFIdrive interface "frame 3". Additional information on using the control and feedback interface is available in the section Configuring (Page 26).

4.5.1 Assignment of the control interface

The user program uses the control interface to influence the behavior of the technology module.

Control interface

The following table shows control interface assignment:

Table 4- 6 Control interface of the technology module

Byte offset from start address ↓	Bit 7	Bit 6	Bit 5	Bit 4	Bit 3	Bit 2	Bit 1	Bit 0
0...1	STW1: Control word 1							
0	Reserved ¹					Control_ by_PLC	Reserved ¹	
1	Fault_ Acknowl- edge	Enable_ Setpoint	Unfreeze_ Ramp_ Generator ⁶	Enable_ Ramp_ Generator	Enable_ Operation	No_Quick_ Stop_OFF3	No_Coast_ Stop_OFF2	On_OFF1
2...5	NSOLL_B: DINT: Normalized speed setpoint in N4 format							
6...7	STW2: Control word 2							
6	UINT: Master_Sign-Of-Life				Reserved ¹			
7	Reserved ¹							

Byte offset from start address ↓	Bit 7	Bit 6	Bit 5	Bit 4	Bit 3	Bit 2	Bit 1	Bit 0
8...9	G1_STW: Encoder control word							
8	Acknowledging_Sensor_Error	Activate_Parking_Sensor ⁷	Request_Absolute_value_Cyclically ³	Request_Set_Home_Position ²	Home_Position_Mode ²	Reserved ¹		
9	Mode	Command_2_Request	Command_1_Request	Command_0_Request	Function_4_Request ^{4,5}	Function_3_Request ^{4,5}	Function_2_Request ⁵	Function_1_Request

- 1 Must be set to 0.
- 2 This command is not supported by the module. If you set the bit, error code F01H is returned in G1_XIST2.
- 3 This command is not supported by the module. If you set the bit, error code 8H is returned in G1_XIST2.
- 4 This command is not supported for the "Acquire measuring input value" function. If you set the bit, error code 6H is returned in G1_XIST2.
- 5 This command is not supported for the "Detect reference mark" function. If you set the bit, error code 4H is returned in G1_XIST2.
- 6 This command is not supported by the module. The bit is not evaluated.
- 7 This command is not supported by the module. If you set the bit, error code 3H is returned in G1_XIST2.

Description of control bits

Control bit/value	Description
STW1	
Control_by_PLC	0 means: Coast Stop (OFF2): Pulse output cannot be controlled by the user program on the CPU. 1 means: Valid values for control of the pulse output will be sent to the module from the user program on the CPU.
On_OFF1	0 means: OFF1: The pulse output returns to state S2 (Page 42). If you are using a drive enable, the corresponding digital output is reset as soon as the drive comes to a standstill. 1 means: Pulse output is switched on.
No_Coast_Stop_OFF2	0 means: Coast Stop (OFF2): The pulse output is stopped and returns to state S1 (Page 42). If you are using a drive enable, the corresponding digital output is reset immediately. 1 means: The "Coast Stop (OFF2)" command is withdrawn.
No_Quick_Stop_OFF3	0 means: Quick stop (OFF3): The drive stops within the configured quick stop time. The pulse output is stopped and returns to state S1 (Page 42). If you are using a drive enable, the corresponding digital output is reset as soon as the drive comes to a standstill. 1 means: The "Quick stop (OFF3)" command is withdrawn.
Enable_Operation	0 means: The pulse output returns to state S3 (Page 42). 1 means: Pulse output is enabled. The drive accelerates to the speed setpoint.

4.5 Control and feedback interface

Control bit/value	Description
Enable_Ramp_Generator	0 means: The pulse output is stopped but remains in state S4 (Page 42). 1 means: Each speed change is controlled along on a ramp by the ramp generator.
Enable_Setpoint	0 means: The ramp generator stops the drive within the configured ramp stop time. State S4 (Page 42) is retained. 1 means: The speed setpoint is specified in NSOLL_B for the ramp generator.
Fault_Acknowledge	You use this bit to acknowledge an error.
NSOLL_B	You use this value to specify the setpoint for the drive axis velocity as a percentage in N4 format. The permitted value range for the speed setpoint is -200% ... +200% ¹ of the reference speed. The DINT value maps the value range linearly. This means 100% corresponds to the value 40000000 _H . The resolution is $9.3 \cdot 10^{-8}\%$.
STW2	
Master_Sign-Of-Life	When you control the module in isochronous mode using technology objects, this value is used by the technology object as the Master sign-of-life. When you control the module in non-isochronous mode without technology objects, you must set this value to 0. When you control the module in isochronous mode without a technology object, we recommend that you also set this value to 0.
G1_STW	
Acknowledging_Sensor_Error	You use this bit to acknowledge an error that occurred during feedback of the actual encoder value.
Function_1_Request	When you use the "Reference mark search" function, you use this bit to specify that the reference mark is to be detected using the configured edge (Page 56) of reference switch input DIn.0 and saved in G1_XIST2. When you use the "Measurement on the fly" function, you use this bit to specify that a measuring input value is to be acquired using the positive edge of digital input DIn.1 and saved in G1_XIST2.
Function_2_Request	You use this bit to specify that a measuring input value is to be acquired using the negative edge of digital input DIn.1.
Command_0_Request, Command_1_Request, Command_2_Request	You use this value to specify how the function selected with the Mode bit will be used: 000 means: Do nothing 001 means: Enable function 010 means: Read out value in G1_XIST2 011 means: Disable function 100 to 111 means: Invalid
Mode	0 means: Reference mark search: Detect reference mark using the configured edge of reference switch input DIn.0 1 means: Measurement on the fly: Acquire measuring input value using measuring input DIn.1

¹ The exact maximum speed setpoint is $+(200 - 2^{-30})\%$

Reference mark search

The following figure shows an example of the sequence of the detection and readout of the reference mark:

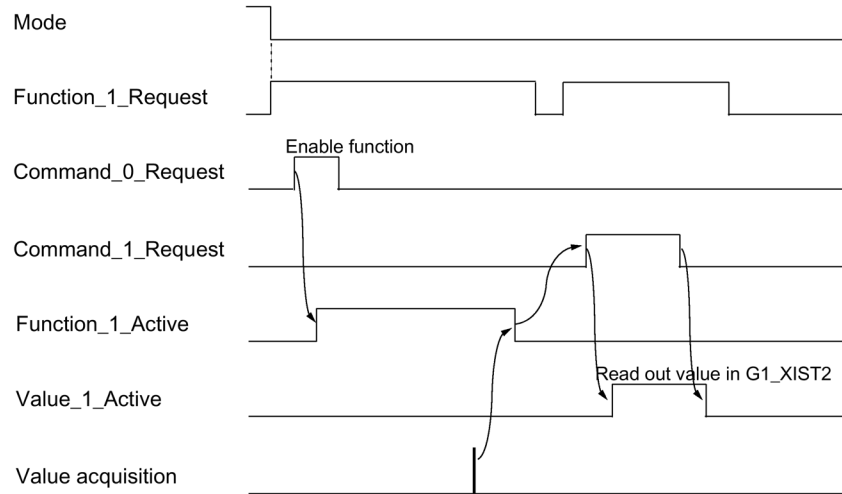

Figure 4-1 Detecting the reference mark

Measurement on the fly

The following figure shows an example of the sequence of the acquisition and the readout of the measuring input value:

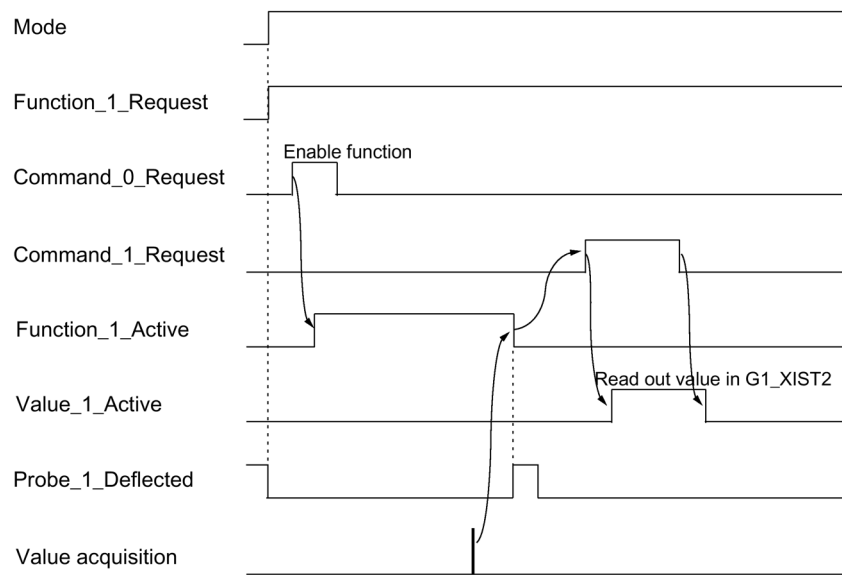

Figure 4-2 Acquiring the measuring input value

4.5.2 Assignment of the feedback interface

The user program receives current values and status information from the technology module by means of the feedback interface.

Feedback interface

The following table shows the assignment of the feedback interface:

Table 4- 7 Feedback interface of the technology module

Byte offset from start address ↓	Bit 7	Bit 6	Bit 5	Bit 4	Bit 3	Bit 2	Bit 1	Bit 0
0...1	ZSW1: Status word 1							
0	Reserved					f_or_n_reached_or_exceeded	Control_Requested	Reserved
1	Reserved	Switching_On_Inhibited	Quick_Stop_Not_Activated_OFF3	Coast_Stop_Not_Activated_OFF2	Fault_Present	Operation_Enabled	Ready_To_Operate	Ready_To_Switch_On
2...5	NIST_B: DINT: Current normalized actual speed value in N4 format							
6...7	ZSW2: Status word 2							
6	UINT: Slave_Sign-Of-Life				Reserved			
7	Reserved							
8...9	G1_ZSW: Encoder status word							
8	Sensor_Error	Parking_Sensor_Executed ¹	Transmit_Absolute_Value_Cyclically ¹	Reserved	Requirement_of_Acknowledgement_Detected	Reserved		Probe_1_Deffected
9	Reserved		Value_2_Active	Value_1_Active	Reserved		Function_2_Active	Function_1_Active
10...13	G1_XIST1: DINT: Current actual encoder value							
14...17	G1_XIST2: DINT: Error code or measuring input value or reference mark							

¹ Not supported by the module.

Description of feedback bits

Feedback bit/value	Description
ZSW1	
Control_Requested	This bit indicates that the module is ready to receive values from the user program for controlling the pulse output.
f_or_n_reached_or_exceeded	This bit indicates that the actual speed value has reached or exceeded the configured maximum speed.
Ready_To_Switch_On	This bit indicates that the pulse output is ready to switch on.
Ready_To_Operate	This bit indicates that the pulse output is ready to operate.
Operation_Enabled	This bit indicates that operation of the drive is enabled and the speed setpoint is being output.
Fault_Present	This bit indicates that a fault has occurred in the supply voltage or at a digital output. Error code 1 _H is returned.
Coast_Stop_Not_Activated_OFF2	This bit indicates that the drive will not perform a Coast Stop (OFF2).
Quick_Stop_Not_Activated_OFF3	This bit indicates that the drive will not perform a Quick Stop (OFF3)
Switching_On_Inhibited	This bit indicates that the pulse output is not yet ready to switch on.
NIST_B	This value indicates the actual value of the drive axis velocity as a percentage in N4 format relative to the reference speed.
ZSW2	
Slave_Sign-Of-Life	When you control the module in isochronous mode using technology objects, this value is used by the technology object as the Slave sign-of-life. When you control the module without technology objects, this bit is set to 0.
G1_ZSW	
Probe_1_Deflected	When you use the "Measurement on the fly" function, this bit indicates the state of digital input DIn.1.
Requirement_of_Acknowledgement_Detected	This bit indicates that the acknowledgement of an error is being processed.
Sensor_Error	This bit indicates that an error has occurred during feedback of position value G1_XIST1. The meaning of the returned error codes can be found in the following table.
Function_1_Active	If you use the "Reference mark search" function, this bit indicates that use of reference switch input DIn.0 is enabled. When you use the "Measurement on the fly" function, this bit indicates that use of the positive edge of measurement sensing input DIn.1 is enabled.
Function_2_Active	This bit indicates that use of the negative edge of measurement sensing input DIn.1 is enabled.
Value_1_Active	When you use the "Reference mark search" function, this bit indicates that the reference mark has been saved in G1_XIST2 using reference switch input DIn.0. When you use the "Measurement on the fly" function, this bit indicates that a measuring input value has been saved in G1_XIST2 using the positive edge of digital input DIn.1.
Value_2_Active	This bit indicates that a measuring input value has been saved in G1_XIST2 using the negative edge of digital input DIn.1.

Feedback bit/value	Description
G1_XIST1	This value is the incremental actual position value. G1_XIST1 corresponds to the number of output pulses, which control the speed of the drive.
G1_XIST2	If an error has occurred, G1_XIST2 indicates the associated error code. For the meaning of the error codes, see the table below. When you use the "Reference mark search" function, this value returns the detected reference mark. When you use the "Measurement on the fly" function, this value returns the acquired measuring input value.

Error codes

G1_XIST2 can contain the following error codes:

Error code	Name	Meaning
1H	Sensor group error	G1_XIST1 is invalid. One of the following errors occurred during feedback of the actual position value. <ul style="list-style-type: none"> • Missing supply voltage • Undervoltage • Short-circuit or overload at the digital output
3H	Sensor pause failed	A sensor pause (Sensor parking) is not supported.
4H	Reference mark detection aborted	<ul style="list-style-type: none"> • The Function_2_Request, Function_3_Request or Function_4_Request bit was set to 1 while the "Reference mark search" function was active. • The Mode bit was set to 1 while the "Reference mark search" function was active. • CPU STOP while the "Reference mark search" function was active.
5H	Read reference mark aborted	<ul style="list-style-type: none"> • G1_XIST2 does not contain a valid value for the reference mark. • The Mode bit was set to 1 while the reference mark was being read from G1_XIST2. • CPU STOP while the reference mark was being read from G1_XIST2.
6H	Measuring input value acquisition aborted	<ul style="list-style-type: none"> • The Function_3_Request or Function_4_Request bit was set to 1 while the "Measurement on the fly" function was active. • The Mode bit was set to 0 while the "Measurement on the fly" function was active. • CPU STOP while the "Measurement on the fly" function was active.

Error code	Name	Meaning
7H	Read measuring input value aborted	<ul style="list-style-type: none"> • G1_XIST2 does not contain a valid value of the measuring input. • The Mode bit was set to 0 while the measuring input value was being read from G1_XIST2. • CPU STOP while the measuring input value was being read from G1_XIST2.
8H	Absolute value acquisition aborted	The Request_Absolute_value_Cyclically bit is not supported by the module. The module returns only incremental encoder values.
F01H	Command not supported	The command is not supported by the module.
F02H	Sign-of-life error (Master Sign-Of-Life)	The number of tolerated errors of the Master sign-of-life (control value Master_Sign-Of-Life) was exceeded.

Procedure

To enable the pulse output, follow these steps:

1. Set the Control_by_PLC, Enable_Setpoint and Enable_Ramp_Generator control bits to TRUE and the On_OFF1, No_Coast_Stop_OFF2, No_Quick_Stop_OFF3 and Enable_Operation bits to FALSE.
State S1 is reached: Switching on of the pulse output is still inhibited. The feedback bit Switching_On_Inhibited is set to TRUE.
2. Set the On_OFF1 and No_Quick_Stop_OFF3 control bits to TRUE.
State S2 is reached: The pulse output is ready to switch on. The feedback bit Ready_To_Switch_On is set to TRUE. The feedback bit Switching_On_Inhibited is set to FALSE.
3. Set the On_OFF1 control bit to TRUE.
State S3 is reached: The pulse output is ready to switch on. The feedback bit Ready_To_Operate is set to TRUE.
4. Set the Enable_Operation control bit to TRUE.
5. If you have configured a drive enable output, set it to high level.
The drive is enabled.
6. If you have configured a ready input, wait for the ready signal of the drive.
As soon as the ready input is at high level, state S4 is reached: Operation is enabled. The pulse output starts. The feedback bit Operation_Enabled is set to TRUE.

Interrupts/diagnostic alarms

5.1 Status and error displays

LEDs

The figure below shows the LED displays (status and error displays) of the TM PTO 4.

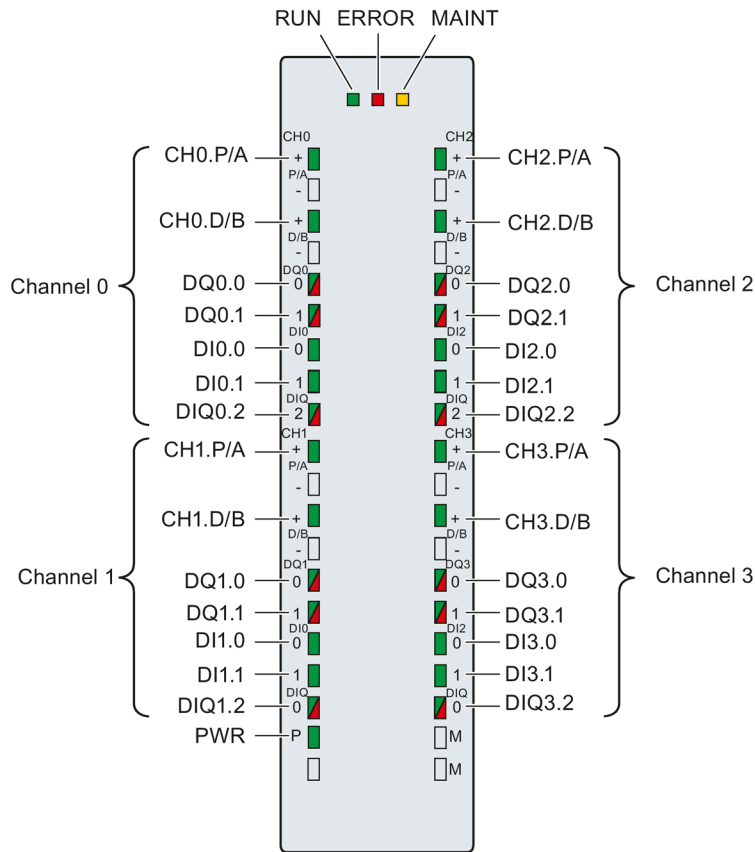

Figure 5-1 LED displays of the TM PTO 4

Meaning of the LED displays

The following tables explain the meaning of the status and error displays. Remedial measures for diagnostic alarms can be found in the section Diagnostic alarms (Page 47).

Table 5- 1 Status and error displays RUN/ERROR/MAINT





















LEDs			Meaning	To correct or avoid errors
RUN	ERROR	MAINT		
 Off	 Off	 Off	No voltage or too low voltage on back-plane bus	<ul style="list-style-type: none"> Switch on the CPU/IM and/or the system power supply modules. Check whether the voltage connectors are inserted. Check whether too many modules are inserted.
 Flashes	 Off	 Off	Technology module starts up and flashes until completion of the valid parameter assignment	—
 On	 Off	 Off	The parameters of the technology module have been assigned.	—
 On	 Flashes	 Off	Indicates module errors (an error is present on at least one channel)	Evaluate the diagnostic alarms and eliminate the error.
 Flashes	 Flashes	 Flashes	Hardware or firmware defective	Replace the technology module.

Table 5- 2 PWR/ERROR status displays

LEDs		Meaning	To correct or avoid errors
PWR	ERROR		
 Off	 Flashes	Supply voltage too low or missing	<ul style="list-style-type: none"> Check the supply voltage. Make sure that the front connector is correctly inserted.
 On	 Off	Supply voltage is present and OK	—
 On	 Flashes	Indicates module errors (an error is present on at least one channel)	Evaluate the diagnostic alarms and eliminate the error.

Channel LEDs

The CHn.P/A, CHn.D/B, and DIn.m LEDs and the LEDs of DIQn.2 used as digital inputs indicate the current level of the associated signals. The LEDs of digital outputs DQn.m and of DIQn.2 used as digital outputs indicate the desired state.

The flashing frequency of the channel LEDs is limited to approximately 24 Hz. If higher frequencies are present, the channel LEDs do not indicate the current status but instead flash at 24 Hz.

Table 5-3 Status displays CHn.m/DIn.m/DQn.m/DIQn.2

LEDs CHn.m/DIn.m/ DQn.m/DIQn.2	Meaning	To correct or avoid errors
□ Off	Pulse output/digital input/digital output at 0 level	—
■ On	Pulse output/digital input/digital output at 1 level	—
■ On (DQn.m/DIQn.2)	Diagnostic alarm: e.g. "Error at digital outputs"	<ul style="list-style-type: none"> • Evaluate the diagnostic alarm. • Check the wiring or the connected load.

5.2 Diagnostic alarms

Enabling the diagnostic interrupts

You enable the diagnostic interrupts at the basic parameters.

The technology module can trigger the following diagnostic interrupts:

Table 5- 4 Possible diagnostic interrupts

Diagnostic interrupt	Monitoring
<ul style="list-style-type: none"> Parameter assignment error Internal error Watchdog tripped. Module is defective. 	Monitoring is always active. A diagnostic interrupt is triggered each time an error is detected.
<ul style="list-style-type: none"> Supply voltage missing Error at the digital outputs 	Monitoring is always active. A detected error only triggers a diagnostic interrupt if "Enable diagnostic interrupts" has been enabled during device configuration. The diagnostic interrupts are not enabled in the default setting.

Reactions to a diagnostic interrupt

The following happens when an event occurs that triggers a diagnostic interrupt:

- The ERROR LED flashes.
Once you have remedied the error, the ERROR LED goes out.
- The S7-1500 CPU interrupts processing of the user program. The diagnostic interrupt OB (e.g. OB 82) is called. The event that triggered the interrupt is entered in the start information of the diagnostic interrupt OB.
- The S7-1500 CPU remains in RUN even if no diagnostic interrupt OB is present in the CPU. The technology module continues working unchanged if this is possible despite the error.

Detailed information on the error event is available with the instruction "RALRM" (read additional interrupt information).

Diagnostic alarms

The diagnostics are displayed as plain text in STEP 7 (TIA Portal) in the online and diagnostics view. You can evaluate the error codes with the user program. The respective channel number is shown for each diagnostic information.

The following diagnostics can be signaled:

Table 5- 5 Diagnostic alarms, their meaning and remedies

Diagnostic alarm	Error code	Meaning	To correct or avoid errors
Parameter as-assignment error	10H	Received parameter data record invalid	Check parameter data record
Supply voltage missing	11H	Undervoltage	Check supply voltage L+
		Wiring of supply voltage L+ faulty	Check wiring of supply voltage L+
		Supply voltage L+ of the technology module missing	Feed supply voltage L+ to the technology module via terminal 41
		Front connector not inserted correctly	Insert front connector correctly
Internal error	100H	Technology module defective	Replace technology module
Watchdog tripped. Module is defective.	103H	Firmware error	Run firmware update
		Technology module defective	Replace technology module
Error at the digital outputs ^{1,2}	10FH	<ul style="list-style-type: none"> • Error at the digital outputs (LED display DQn.m lights up red) • Possible causes: <ul style="list-style-type: none"> – Short-circuit – Overload 	<ul style="list-style-type: none"> • Correct wiring at the digital outputs • Check consumers connected to the digital outputs

¹ Digital outputs DQ0.0, DQ0.1, DQ1.0 and DQ1.1 have shared diagnostics. Digital outputs DQ2.0, DQ2.1, DQ3.0 and DQ3.1 have shared diagnostics.

² Diagnostics for short-circuit and overload are effective only for 24 V outputs and only up to an output frequency of approximately 100 Hz. The module is otherwise protected from irrevocable damage caused by short-circuit at the outputs, and the diagnostic alarm is not displayed.

 CAUTION
<p>Cross-channel diagnostics of the digital outputs</p> <p>The digital outputs of channels 0 and 1 as well as channels 2 and 3 have shared diagnostics. As a result, when there is an error at one digital output, faults are automatically signaled for <i>two</i> channels and the pulse output of both channels is stopped.</p> <p>Ensure that this fault scenario is taken into consideration when using multiple channels.</p>

Technical specifications

6ES7553-1AA00-0AB0	
General information	
Product type designation	TM PTO 4
Number of channels	4; axes
Product function	
I&M data	Yes; I&M0 to I&M3
Isochronous mode	Yes
Engineering with	
STEP 7 TIA Portal can be configured/integrated as of version	STEP 7 V14
STEP 7 can be configured/integrated as of version PROFINET as of GSD version/GSD revision	V5.5 SP3 with GSD file / - GSDML V2.32
Installation type/mounting	
Rail mounting possible	Yes; S7-1500 mounting rail
Supply voltage	
Load voltage L+	
Rated value (DC)	24 V
Low limit of valid range (DC)	19.2 V
High limit of valid range (DC)	28.8 V
Reverse polarity protection	Yes
Input current	
Current consumption, max.	70 mA; without load
Power	
Power from the backplane bus	1.3 W
Power loss	
Power loss, typ.	4 W
Address area	
<ul style="list-style-type: none"> • Inputs 	18 bytes; per channel
<ul style="list-style-type: none"> • Outputs 	10 bytes; per channel

6ES7553-1AA00-0AB0	
Digital inputs	
Number of inputs	12; 3 per channel, including 1 DIQ
Digital inputs configurable	Yes
Input characteristics to IEC 61131, Type 3	Yes
Digital input functions, configurable	
Synchronization	Yes
Measuring input	Yes
Drive ready	Yes
Input voltage	
Type of input voltage	DC
Nominal value (DC)	24 V
For signal "0"	-5 ... +5 V
For signal "1"	+11 ... +30 V
Permitted voltage at input, min.	-5 V
Permitted voltage at input, max.	30 V
Input current	
for signal "1", typ.	2.5 mA
Input delay (at rated value of input voltage)	
For standard inputs	
<ul style="list-style-type: none"> Configurable 	Yes; none / 0.05 / 0.1 / 0.4 / 0.8 / 1.6 / 3.2 / 12.8 / 20 ms
<ul style="list-style-type: none"> at "0" to "1", min. 	4 µs; with parameter assignment "none"
<ul style="list-style-type: none"> at "1" to "0", min. 	4 µs; with parameter assignment "none"
For technological functions	
<ul style="list-style-type: none"> Configurable 	Yes
Cable length	
Shielded, max.	1000 m
Unshielded, max.	600 m
Digital outputs	
Number of outputs	12; 3 per channel, including 1 DIQ
<ul style="list-style-type: none"> In groups of 	
Current sinking	Yes; push-pull for DQn.0 und DQn.1
Current sourcing	Yes
Digital outputs configurable	Yes
Short-circuit protection	
<ul style="list-style-type: none"> Response threshold, typ. 	0.2 A for DQn.0 and DQn.1, 0.9 A for DIQn.2
Control of a digital input	Yes

	6ES7553-1AA00-0AB0
Digital output functions, configurable	
PTO (Pulse Train Output) signal interface	
• 24 V asymmetrical	Yes
• RS 422 symmetrical	Yes
• TTL (5 V) asymmetrical	Yes; min. 2.4 V, min. 220 ohm
PTO (Pulse Train Output) signal type	
• Pulse and direction	Yes
• Count up, count down	Yes
• Incremental encoder (A, B phase-shifted)	Yes
• Incremental encoder (A, B phase-shifted, quadruple)	Yes
Output switching capacity	
With resistive load, max.	0.1 A; 0.5 A for DIQn.2
With lamp load, max.	1 W; 5 W for DIQn.2
Load resistance range	
Low limit	240 Ω; 48 Ω for DIQn.2
High limit	12 kΩ
Output voltage	
Type of output voltage	DC
for signal "1", min.	23 V; L+ (-2.0 V)
Output current	
for signal "1" rated value	0.1 A; 0.5 A for DIQn.2
for signal "1" permissible range, max.	0.12 A; 0.6 A for DIQn.2
for signal "1" minimum load current	2 mA
for signal "0" residual current, max.	0.5 mA
Output delay with resistive load	
"0" to "1", typ.	1 μs; 28 μs for DIQn.2
"1" to "0", typ.	1 μs; 25 μs for DIQn.2
Switching frequency	
With resistive load, max.	1 kHz; for DIQn.2
With inductive load, max.	0.5 Hz; according to IEC 60947-5-1, DC-13, for DIQn.2
With lamp load, max.	10 Hz; for DIQn.2
With 24 V asymmetrical signal interface	200 kHz; for DQn.0 and DQn.1
With RS 422 symmetrical signal interface	1 MHz
With TTL (5 V) asymmetrical signal interface	200 kHz
Cable length	
Shielded, max.	320 m; RS422 / TTL Siemens Type 6FX2001-5: 125 kHz, 320 m; 250 kHz, 160 m; 500 kHz, 60 m; 1 MHz, 32 m; 24 V (DQn.m / DIQn.2): 10 kHz, 600 m; 200 kHz, 50 m

6ES7553-1AA00-0AB0	
Isochronous mode	
Isochronous mode (application synchronized until terminal)	Yes
Bus cycle time (TDP), min.	250 µs; 375 µs, when all 4 channels are used
Jitter, max.	1 µs
Interrupts/diagnostics/status information	
Diagnostics function	Yes
Interrupts	
Diagnostic interrupt	Yes
Diagnostic alarms	
Monitoring of supply voltage	Yes
Short-circuit	Yes; thermal overload protection
Group error	Yes
LED diagnostics display	
RUN LED	Yes; green LED
ERROR LED	Yes; red LED
MAINT LED	Yes; yellow LED
Monitoring of supply voltage (PWR LED)	Yes; green LED
Channel status display	Yes; green LED
For channel diagnostics	Yes; red LED
Electrical isolation	
Electrical isolation channels	
Between channels	No
Between the channels and backplane bus	Yes
Between the channels and load voltage L+	No
Isolation	
Isolation tested with	707 V DC (type test)
Ambient conditions	
Ambient temperature in operation	
Horizontal installation, min.	0 °C
Horizontal installation, max.	60 °C; note derating
Vertical installation, min.	0 °C
Vertical installation, max.	40 °C; note derating
Distributed operation	
on SIMATIC S7-300	Yes; via control and feedback interface
on SIMATIC S7-400	Yes; via control and feedback interface
on SIMATIC S7-1200	Yes
on SIMATIC S7-1500	Yes
on Standard PROFINET Controller	Yes; via control and feedback interface

6ES7553-1AA00-0AB0	
Dimensions	
Width	35 mm
Height	147 mm
Depth	129 mm
Weights	
Weight, approx.	300 g

Note

Derating information for output current

In the following cases, the maximum output current is reduced to 0.05 A for digital outputs DQn.m and 0.1 A for digital outputs DIQn.2:

- When the system is mounted vertically, as of an ambient temperature of 30 °C.
In addition, you may only use channels 0 to 2 in this case.
- When the system is mounted horizontally, as of an ambient temperature of 50 °C.

Dimensional drawing

A

The dimensional drawing of the module on the mounting rail, as well as a dimensional drawing with open front panel, are provided in the appendix. Always observe the specified dimensions for installation in cabinets, control rooms, etc.

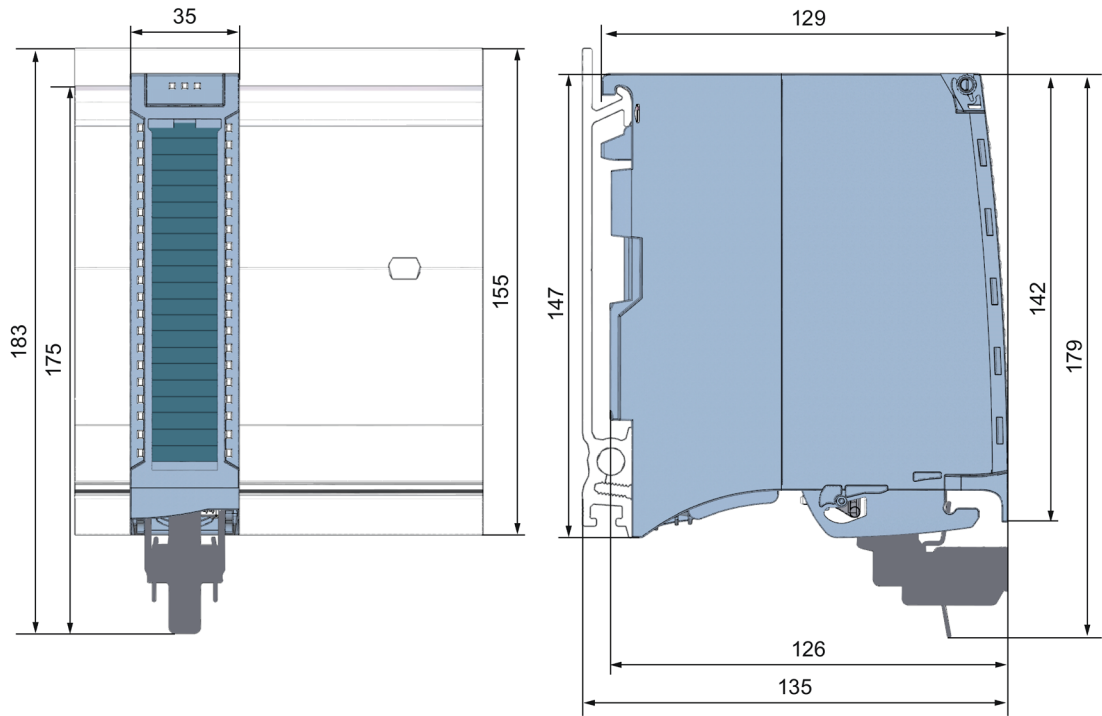

Figure A-1 Dimensional drawing of technology module TM PTO 4

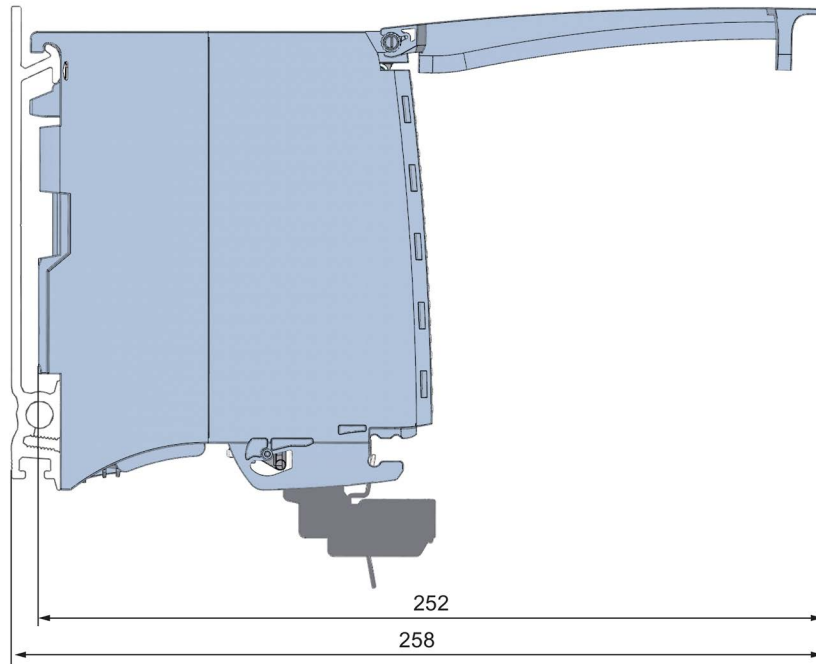

Figure A-2 Dimensional drawing of the TM PTO 4 module, side view with open front panel

Parameter data record

B.1 Parameter assignment and structure of the parameter data record

You have the option to change the parameter assignment of the module with the user program while the CPU is in RUN. The parameters are transferred to the module using the using data record 128, for example with the instruction WRREC.

If errors occur during the transfer or validation of parameters with the WRREC instruction, the module continues operation with the previous parameter assignment. A corresponding error code is then written to the STATUS output parameter. If no errors occur, the STATUS output parameter contains the length of the actually transferred data.

The description of the WRREC instruction and the error codes is available in the section Parameter validation error (Page 61) or in the online help of STEP 7 (TIA Portal).

Structure of data record 128

The following tables show you the structure of data record 128 for TM PTO 4. The values in byte 0 to byte 3 are fixed and may not be changed. The channels are assigned in ascending order.

Note

The impulse output will be stopped for transfer of data record 128. For this reason, only transfer the data record when the drive is at a standstill.

Note

If you are using less than four channels, data record 128 is shortened accordingly.

When using the technology module on PROFIBUS DP, you can use a maximum of three channels.

B.1 Parameter assignment and structure of the parameter data record

Table B- 1 Parameter data record 128: Overall module

Bit →	Bit 7	Bit 6	Bit 5	Bit 4	Bit 3	Bit 2	Bit 1	Bit 0
Byte ↓								
0...3	Header							
0	Major Version = 0				Minor Version = 1			
1	Length of parameter data per channel = 28							
2	Reserved ²							
3	Reserved ²							
4...31	Channel 0							
32...59	Channel 1 (if used)							
60...87	Channel 2 (if used)							
88...115	Channel 3 (if used)							

² Reserved bits must be set to 0.

Table B- 2 Parameter data record 128: Channel parameters

Bit →	Bit 7	Bit 6	Bit 5	Bit 4	Bit 3	Bit 2	Bit 1	Bit 0
Byte ↓								
	Basic parameters							
4/32/ 60/88	Reserved ²				Enable diagnostic interrupts ¹	Reaction to CPU STOP:		
						000 _B : Coast Stop and reset drive enable 001 to 111 _B : Invalid		
	Operating mode							
5/33/ 61/89	Reserved ²	Signal inter- face:	Signal evaluation ³		Signal type:			
			00 _B : Single		0000 _B : Invalid			
		0 _B : 24 V, asymmet- rical	01 _B : Invalid		0001 _B : Pulse (P) and direction (D)			
			10 _B : Quadruple		0010 _B : Count up (A), count down (B)			
	1 _B : RS422, symmetrical / TTL (5 V), asymmet- rical	11 _B : Invalid		0011 _B : Incremental encoder (A, B phase-shifted)				
					0100 to 1111 _B : Invalid			

B.1 Parameter assignment and structure of the parameter data record

Bit →	Bit 7	Bit 6	Bit 5	Bit 4	Bit 3	Bit 2	Bit 1	Bit 0
Byte ↓	Bit 7	Bit 6	Bit 5	Bit 4	Bit 3	Bit 2	Bit 1	Bit 0
Digital inputs								
6/34/ 62/90	Reference switch edge selection:				Input delay:			
					0000 _B : None			
	0001 _B : 0.05 ms							
	0 _B : At positive edge				0010 _B : 0.1 ms			
					0011 _B : 0.4 ms			
	1 _B : At negative edge				0100 _B : 0.8 ms			
					0101 _B : 1.6 ms			
	0110 _B : 3.2 ms							
	0111 _B : 12.8 ms							
	1000 _B : 20 ms							
1001 to 1111 _B : Invalid								
Values								
7/35/ 63/91	Interpulse period at direction reversal: UINT: Value range in ms: 0 to 255 _D							
8...11/ 36...39/ 64...67/ 92...95	Reference speed: REAL: Value range in rpm: 1.0 to 20000.0 _D :							
12...15/ 40...43/ 68...71/ 96...99	Increments per revolution: DINT: Value range in rpm: 1 to 1000000 _D							
16...19/ 44...47/ 72...75/ 100...103	Maximum speed: REAL: Value range is dependent on signal interface, signal evaluation, increments per revolution and reference speed, see following table							
20...21/ 48...49/ 76...77/ 104...105	Quick stop time (OFF3): UINT: Value range in ms: 1 to 65535 _D							
22...23/ 50...51/ 78...79/ 106...107	Ramp stop time (OFF1): UINT: Value range in ms: 1 to 65535 _D							

B.1 Parameter assignment and structure of the parameter data record

Bit →	Bit 7	Bit 6	Bit 5	Bit 4	Bit 3	Bit 2	Bit 1	Bit 0
Byte ↓	Bit 7	Bit 6	Bit 5	Bit 4	Bit 3	Bit 2	Bit 1	Bit 0
	Hardware inputs/outputs							
24...25/ 52...53/ 80...81/ 108...109	Reserved ²							
26/54/ 82/110	Use drive enable ¹	Reserved ²	Drive enable output:					
			00000 _B : DQn.0 ⁴					
			00001 _B : Invalid					
			00010 _B : DIQn.2					
27/55/ 83/111	Use DI0 as reference switch ¹	Reserved ²	Reference switch input:					
			00000 _B : DIn.0					
			00001 to 11111 _B : Invalid					
			Measuring input:					
28/56/ 84/112	Use DI1 as measuring input ¹	Reserved ²	00000 _B : Invalid					
			00001 _B : DIn.1					
			00010 to 11111 _B : Invalid					
			"Drive ready" input:					
29/57/ 85/113	Use "Drive ready" ¹	Reserved ²	00000 _B : DIn.0					
			00001 _B : DIn.1					
			00010 _B : DIQn.2					
			00011 to 11111 _B : Invalid					
30...31/ 58...59/ 86...87/ 114...115	Tolerated number of sign-of-life errors: UINT: Value range: 0 to 65535 _D 65535 _D means: No monitoring for errors of Master sign-of-life							

- 1 You enable the respective parameter by setting the corresponding bit to 1.
- 2 Reserved bits must be set to 0.
- 3 Only available for signal type "Incremental encoder (A, B phase-shifted)"
- 4 Only available for "RS422, symmetrical / TTL (5 V), asymmetrical" signal interface

Maximum speed

The following table shows the calculation of the value range of the maximum speed:

Table B- 3 Value range of the maximum speed

Signal interface	Value range of the maximum speed			
	Low limit		High limit (the smaller of the two values applies)	
	Signal evaluation "Single"	Signal evaluation "Quadruple"	Signal evaluation "Single"	Signal evaluation "Quadruple"
24 V, asymmetrical	0.1 Hz * 60 / (increments per revolution)	0.1 Hz * 60 *4 / (increments per revolution)	<ul style="list-style-type: none"> • 2 * reference speed • 200000 Hz * 60 / (increments per revolution) 	<ul style="list-style-type: none"> • 2 * reference speed • 200000 Hz * 60 *4 / (increments per revolution)
TTL (5 V), asymmetrical			<ul style="list-style-type: none"> • 2 * reference speed • 1000000 Hz * 60 / (increments per revolution) 	<ul style="list-style-type: none"> • 2 * reference speed • 1000000 Hz * 60 *4 / (increments per revolution)
RS422, symmetrical				

B.2 Parameter validation error

If you make the parameter setting in STEP 7 (TIA Portal) , the parameter values are checked before they are transferred to the technology module. This process prevents parameter errors.

In other use cases, the technology module checks the transferred parameter data record. If the technology module finds invalid or inconsistent parameter values, it outputs an error code (see below). The new parameter data record is rejected in this case, and work continues with the current parameter values until a valid parameter data record has been transferred.

WRREC

When the CPU is in RUN, you can change the parameter data record with the instruction WRREC (Write Record). In case of errors, the WRREC instruction returns corresponding error codes in the STATUS parameter.

Example:

Let us assume that when WRREC is executed, an invalid value, for example 9, is written to the module for the signal type. As a consequence, the module rejects the entire parameter data record. You can recognize this by evaluating the STATUS output parameter of the WRREC instruction. The STATUS output parameter is output as an ARRAY[1..4] of BYTE data with the value 16#DF80E111:

Example of WRREC STATUS data	Address	Meaning
DF _H	STATUS[1]	Error when writing a data record via PROFINET IO (IEC 61158-6)
80 _H	STATUS[2]	Error when reading or writing a data record via PROFINET IO (IEC 61158-6)
E1 _H	STATUS[3]	Module-specific error
13 _H	STATUS[4]	Error code from the table below: The "Signal type" parameter has an invalid value.

Error codes

The following table shows the module-specific error codes and their meaning for parameter data record 128.

Table B- 4 Error codes for parameter validation

Error code in STATUS parameter (hexadecimal)				Meaning	Remedy
Byte 0	Byte 1	Byte 2	Byte 3		
DF	80	B0	00	Data record number unknown	Enter valid number for data record
DF	80	B1	00	Length of data record incorrect	Enter valid value for data record length.
DF	80	B2	00	Slot invalid or not accessible	<ul style="list-style-type: none"> Check whether module is inserted or removed. Check assigned values for parameters of the WRREC instruction.
DF	80	E0	01	Wrong version	<ul style="list-style-type: none"> Check byte 0. Enter valid values.
DF	80	E0	02	Error in the header information	<ul style="list-style-type: none"> Check byte 1. Correct length of parameter blocks.
DF	80	E1	00	Parameter invalid: No detailed information available	Check all parameter values.
DF	80	E1	12	"Reaction to CPU STOP" parameter invalid	Enter parameter value 000 _B .
DF	80	E1	13	"Signal type" parameter invalid	Enter valid parameter value.
DF	80	E1	1A	"Input delay" parameter invalid	Enter valid parameter value.
DF	80	E1	26	"Reference speed" parameter invalid	Enter parameter value from range 1.0 to 20000.0 _D taking into account the dependencies (Page 60).
DF	80	E1	29	"Increments per revolution" parameter invalid	Enter parameter value from range 1 to 1000000 _D taking into account the dependencies (Page 60).
DF	80	E1	50	"Maximum speed" parameter invalid	Enter parameter value from the valid range (Page 60) in each case.
DF	80	E1	51	"Quick stop time (OFF3)" parameter invalid	Enter parameter value from range 1 to 65535 _D .
DF	80	E1	52	"Ramp stop time (OFF1)" parameter invalid	Enter parameter value from range 1 to 65535 _D .
DF	80	E1	2C	"Signal evaluation" parameter invalid	Enter valid parameter value.
DF	80	E1	40	"Reference switch input" parameter invalid	Enter valid parameter value.
DF	80	E1	41	"Measuring input" parameter invalid	Enter valid parameter value.
DF	80	E1	44	"Drive enable output" parameter invalid	Enter valid parameter value.
DF	80	E1	45	"Drive ready" input" parameter invalid	Enter valid parameter value.
DF	80	E1	46	DIQn.2 configured as ready input and drive enable output	Configure DIQn.2 either as ready input or as drive enable output.
DF	80	E1	47	<ul style="list-style-type: none"> DIIn.0 configured as reference switch input and ready input DIIn.1 configured as measuring input and ready input 	<ul style="list-style-type: none"> Configure DIQn.0 either as reference switch input or as ready input. Configure DIQn.1 either as measuring input or as ready input.